

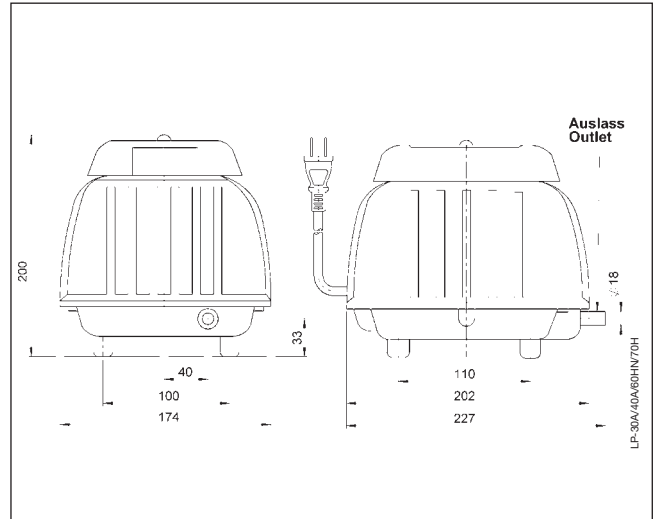

Linear Diaphragm Pumps

LP-30 A, LP-40A, LP-60HN

Flow at rated pressure **36 to 70 l/min**



Pneumatic Data

Description	LP-30A	LP-40A	LP-60HN
Part number	52500030	52500040	52500407
Flow at rated pressure	36 l/min	43 l/min	70 l/min
Rated pressure	120 mbar	120 mbar	150 mbar
Operating range	50 to 200 mbar	50 to 200 mbar	50 to 200 mbar

Electrical Data

Motor type	Linear drive	Linear drive	Linear drive
Voltage	230 V 50/60 Hz	230 V 50/60 Hz	230 V 50/60 Hz
Consumption at free flow	0,5 A/36 W	0,6 A/45 W	0,7 A/70 W
Consumption at rated pressure	0,4 A/29 W	0,5 A/39 W	0,7 A/59 W

General Data

Ambient temperature	-10 to 40 °C	-10 to 40 °C	-10 to 40 °C
Weight	5,0 kg	5,5 kg	6,0 kg
Outlet diameter	18 mm	18 mm	18 mm
Average noise level	32 dB (A)	34 dB (A)	38 dB (A)

Service Parts

Service Parts	Part Numbers		
Chamber block set	700037	700037	700038
Air filter and gaskets kit	700043	700043	700044
Air filter kit	700168	700168	700168
Protective switch	-	-	700115

Please refer to operating instructions and service manual for additional information.

All listed values are measured at standard atmospheric conditions and at 50Hz.

Flow Curves

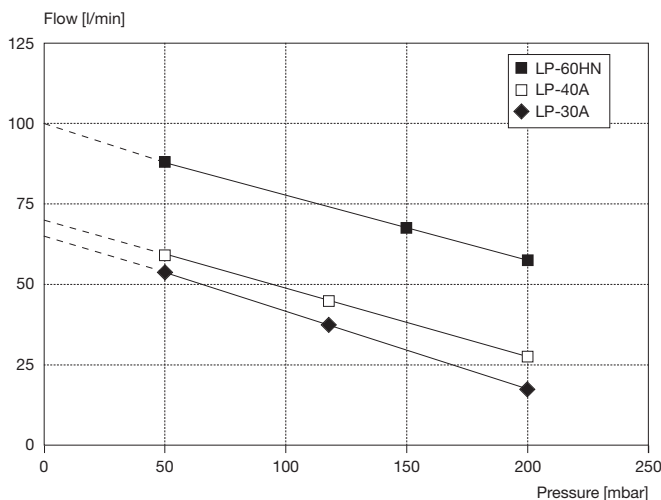

Service parts:

Chamber block consists of:

- 2 x Pump head
- 2 x Valve plate gasket
- 2 x Pump body with valves
- 2 x Diaphragm
- 2 x Diaphragm ring
- 2 x Diaphragm nut
- 2 x Diaphragm washer

Filter and gaskets kit consists of:

- 1 x Air cleaner element
- 1 x Air cleaner gasket
- 1 x Tank gasket
- 2 x L-Hose
- 2 x L-Clamp

Supplied as standard:

Cable/Euro-plug

Air connector (part number 700049)

- consists of:
- 1 x Outlet hose, 180 mm
- 2 x Hose clamp

The information presented in this material is based on technical data and test results of nominal units. It is believed to be accurate and reliable and is offered as an aid to help in the selection of Thomas products. It is the responsibility of the user to determine the suitability of the product for the intended use and the user assumes all risk and liability whatsoever in connection therewith. Thomas does not warrant, guarantee or assume any obligation or liability in connection with this information.

Air filter kit consists of:

- 5 x Air cleaner element
- 5 x Air cleaner gasket

Protective switch consists of:

- 1 x Microswitch with bracket



Gardner Denver Thomas GmbH
Siemensstraße 4
Gewerbegebiet Nord
D-82178 Puchheim

Phone: +49 (89) 8 09 00-0

Fax: +49 (89) 80 83 68

e-Mail: info.puc@rt pumps.com

<http://www.rtpumps.com/puc>